

MICA2DOT

WIRELESS MICROSENSOR MOTE

- ▼ 3rd Generation, Quarter-Sized (25mm), Wireless Smart Sensor
- ▼ TinyOS - Unprecedented Communications and Processing
- ▼ Battery-Powered, Low-Mass
- ▼ Fits Anywhere, Wireless Reprogrammable
- ▼ Wireless Communications with Every Node as Router Capability
- ▼ 433 MHz or 868/916MHz Multi-channel Radio Transceiver (Compatible with MICA2)

Applications

- ▼ Tiny Wireless Sensors
- ▼ Temperature and Environmental Monitoring
- ▼ Data Logging in Hard-to-Reach Places
- ▼ Smart Badges, Wearable Computing
- ▼ Active 2-Way "Smart" Tags

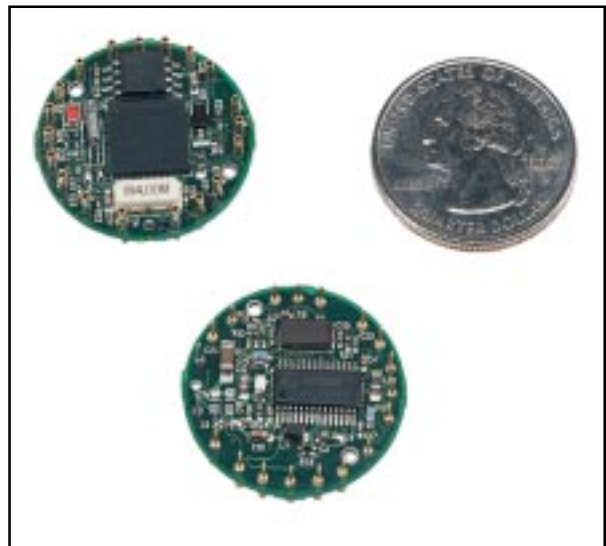
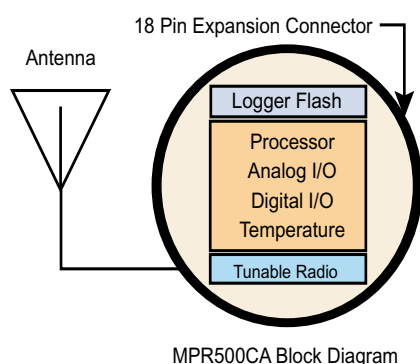

MICA2DOT

The MICA2DOT Mote is a third generation mote module used for enabling low-power, wireless, sensor networks. The MICA2DOT is similar to the MICA2, except for its quarter-sized (25mm) form factor and reduced input/output channels. The following features make the MICA2DOT better suited for commercial deployment;

- 868/916MHz or 433MHz multi-channel transceiver with extended range
- TinyOS (TOS) Distributed Software Operating System v1.0 with improved networking stack and improved debugging features
- Support for wireless remote reprogramming
- Compatible with MICA2 (MPR400) Mote
- On Board Temperature Sensor, Battery Monitor, and LED

TinyOS 1.0 is a small, open-source, energy efficient, software operating system developed by UC Berkeley which supports large scale, self-configuring sensor networks. The source code and software development tools are publicly available at:

<http://webs.cs.berkeley.edu/tos>

Processor and Radio Platform (MPR500CA):

The MPR500CA is based on the Atmel ATmega 128L. The ATmega 128L is a low-power microcontroller which runs TOS from its internal flash memory. Using TOS, a single processor board (MPR500CA) can be configured to run your sensor application/processing and the network/radio communications stack simultaneously. The MICA2DOT features 18 solderless expansion pins for connecting 6 Analog Inputs, Digital I/O, and a serial communication or UART interface. These interfaces make it easy to connect to a wide variety of external peripherals.

Sensor Boards:

Various sensor boards and data acquisition boards are available from Crossbow. These boards connect onto the MICA2DOT through a ring of 18 solderless expansion pins. These pins allow boards to be stacked both above and below the MICA2DOT processor radio board. Crossbow supplies the following expansion boards:

- MDA500CA: Protoboard
- Contact Crossbow for information on other boards

Processor/Radio Board	MPR500CA	MPR510CA	Remarks
Processor Performance			
Program Flash Memory	128K bytes	128K bytes	
Measurement (Serial) Flash	512K bytes	512K bytes	>100,000 Measurements
Configuration EEPROM	4 K bytes	4 K bytes	
Serial Communications	UART	UART	0-3V transmission levels
Analog to Digital Converter	10 bit ADC	10 bit ADC	6 channels, 0-3Vin
Other Interfaces	DIO	DIO	9 channels
Current Draw	8 mA	8 mA	active mode
	< 15 uA	< 15 uA	sleep mode
Multi-Channel Radio			
Center Frequency	868/916 MHz	433 MHz	ISM bands
Number of Channels	> 8, > 100	> 8	programmable, country specific
Data Rate	38.4 Kbaud	38.4 Kbaud	manchester encoded
RF Power	-20 - +5 dBm	-20 - +10 dBM	programmable, typical
Receive Sensitivity	-98 dBm	-101 dBm	typical, analog RSSI at AD Ch. 0
Outdoor Range	500 ft	1000 ft	1/4 Wave dipole, line of sight
Current Draw	27 mA	25 mA	transmit with maximum power
	10 mA	8 mA	receive
	< 1 uA	< 1 uA	sleep
Electromechanical			
Battery	3V Coin Cell	3V Coin Cell	
External Power	2.7 - 3.3 V	2.7 - 3.3 V	connector provided
User Interface	1 LED	1 LED	user programmable
Size (in)	1.0 x 0.25	1.0 x 0.25	excl. battery pack
(mm)	25 x 6	25 x 6	excl. battery pack
Weight (oz)	0.11	0.11	excl. batteries
(grams)	3	3	excl. batteries
Expansion Connector	18 pins	18 pins	all major I/O signals



Base Stations:

The MICA2DOT communicates with base stations that use the MICA2 radio module. These include a standard MICA2 (MPR400CB) mated to a Mote Interface Board (MIB500CA), as well as the MICA-WEB Gateway.

Packaging:

The MICA2DOT is presently distributed as a stand-alone subassembly without packaging. In future, a small plastic housing will be available.

Developers Kits:

Crossbow offers a variety of development kits for the MICA2 and MICA2DOT Motes.

▼ MIB500CA Mote Interface Board



Model	Description
MOTE-KIT5040	Professional Developer's Kit (4X MPR500CA, 4X MPR400CB, 3X MTS310CA, 2X MDA500CA, 1X MIB500CA)
MOTE-KIT5141	Professional Developer's Kit (4X MPR510CA, 4X MPR410CB, 3X MTS310CA, 2X MDA500CA, 1X MIB500CA)
MPR500CA	868/916 MHz Processor/Radio Board
MPR510CA	433 MHz Processor/Radio Board
MDA500CA	MICA2DOT Prototype/Data Acquisition Board
MIB500CA	MICA, MICA2, MICA2DOT Mote Interface & Programming Board

wireless sensor networks