

Check to be sure that there are 5 problems on 5 pages. You are encouraged to answer all 5 problems. Your grade will be based on the four best answers. You have 2 hours. Note that some problems are more time-consuming than others. Use your time wisely. This is an open book and open note examine.

Show all your work. If a problem statement is unclear to you, state your assumptions. If you use additional sheets of paper, identify them and arrange them in sequence.

Write down your name here



work phone or
home phone
(optional)

Problem 1. Trellis Modulation

Assume that the following 8 signal set constellation diagram and state transition diagram are used for trellis modulation, and within 22.5 degrees deviated from the legal signal is considered to be good signal. Bad signal is an indication of out of sync situation between the sender and the receiver. For example, the receiver at state 0 receives a signal with phase angle of 130 degree will be considered as bad signal. The receiver, at state 0, considers signals with the phase angle between 0 and 22.5 degrees, and between 337.5 and 360 degrees as signal 0; signals with the phase angle between 67.5 and 112.5 degrees are considered as signal 2; signals with the phase angle between 157.5 and 202.5 degrees are considered as signal 4; signals with the phase angle between 247.5 and 292.5 degrees are considered as signal 6.

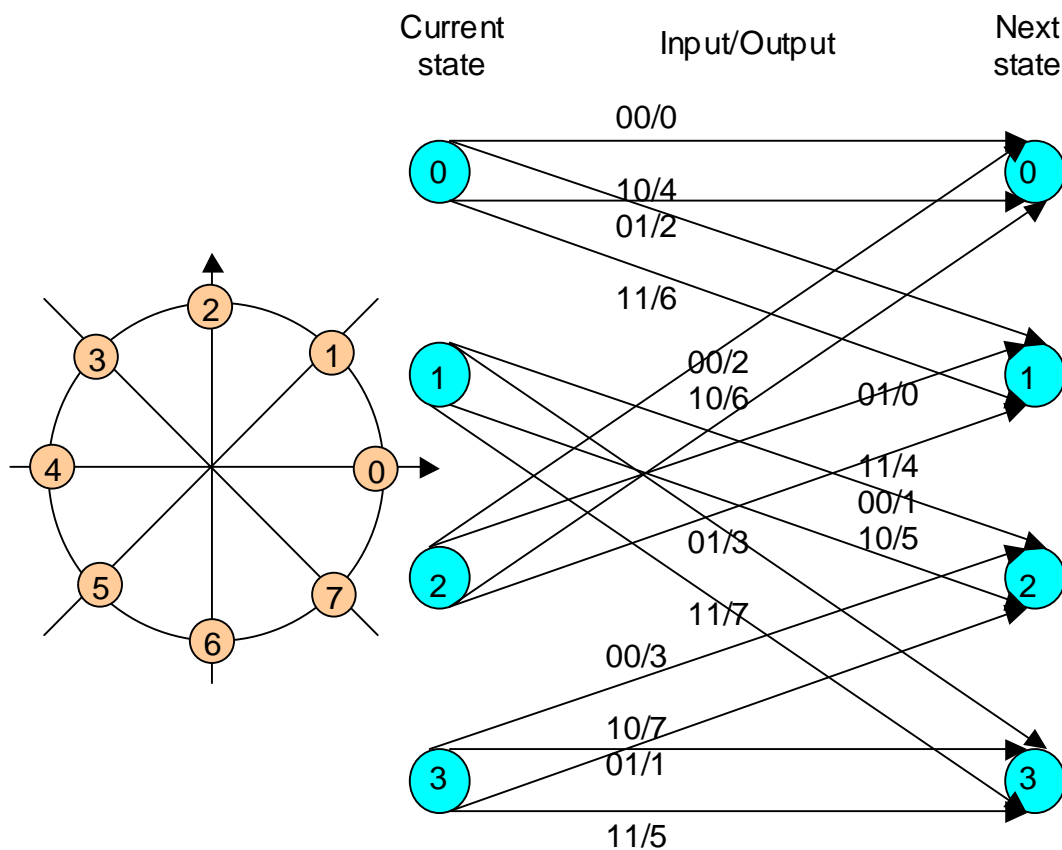

- What signal sequence will be sent out when sender gets 00011011 at state 0?
- What bit patterns should be delivered to the receiver's computer if at state 0, signals with the phase angles, 250, 300, 130, and 80 degrees are received? If out of sync happens, when the receiver detects it.
- What bit patterns should be delivered to the receiver's computer if at state 0, signals with the phase angles, 80, 225, 140, and 170 degrees are received? If out of sync happens, when the receiver detect it.

Problem 2. CRC

Assume Generator Polynomial $G(x)=x^4+x+1$ is used to compute the check sum of the frame.
Show your work.

- a) Given the data 10000000, what is the check sum? What is the codeword to be sent?
- b) The receiver receives 11111000100. Is this a good frame?

Problem 3. Hamming's SECC.

- a) What is the code word for 'd'=1100100 using Richard Hamming's Single Error Correcting Code (SECC)?
- b) When the receiver receives the Hamming's SECC code 10110001001, what are the 7 data bits it should deliver to the upper layer?

Problem 4. EDC vs. ECC.

Assume a channel with the error rate of 10^{-4} , with one million bits of data to send.

- a) If we use EDC with block size of 1000 data bits and one parity bit,
- 1) How many blocks is needed to be sent by the sender, including the retransmission blocks, for correctly delivered all one million bits of data?
 - 2) Do we need an acknowledge channel for using ARQ?
 - 3) What is the overhead in this case?
- b) If we use Hamming's ECC, what will be the block size you would like to choose for optimal performance?

Problem 5. Switching.

a) 12 pts. Given the following 8x8 batcher banyan network and the 3 cell with routing tag. Mark

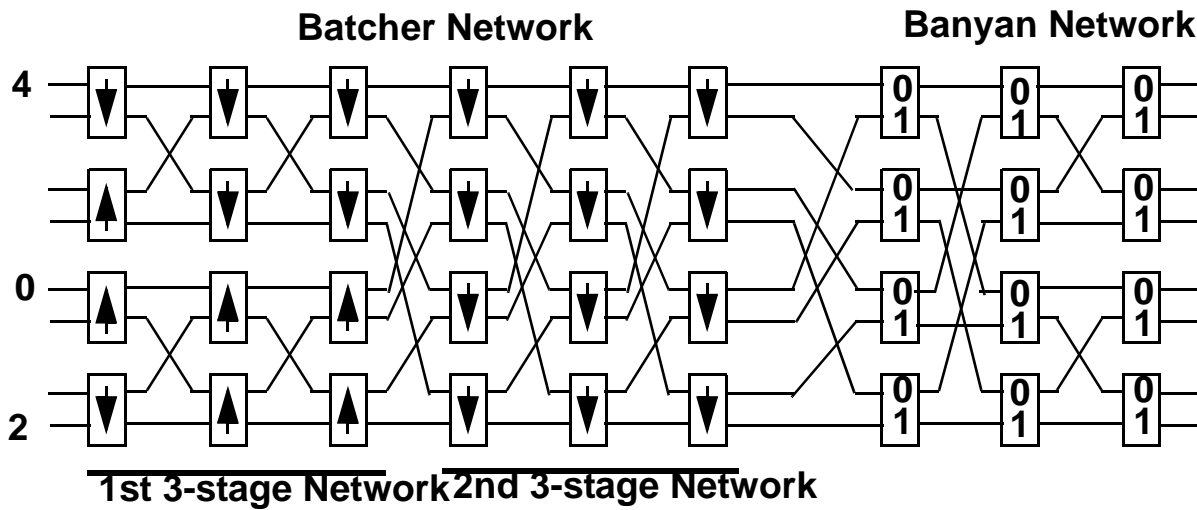

the 2x2 switch configurations (cross-over, or straight through) along their routes to destination ports.