

Building a Single-Cycle Datapath

Set 1

All the Chapter 5 Slides were developed by Capt. Jim Kettner while he was teaching at The United States Air Force Academy. They are being used by permission of USAFA/DFCS

Fall, 2008 cs 216 Datapath - Control Set 1- single cycle 1

Overview

- We'll be implementing a subset of the MIPS ISA
 - What's the difference between architecture and implementation?
- Limited instruction set...
 - memory-reference instructions: `lw`, `sw`
 - arithmetic-logical instructions: `add`, `sub`, `and`, `or`, `sll`
 - control flow instructions: `beq`, `j`
- The datapath will consist of two types of elements:
 - State Elements
 - Combinational Elements
- Single Cycle Datapath

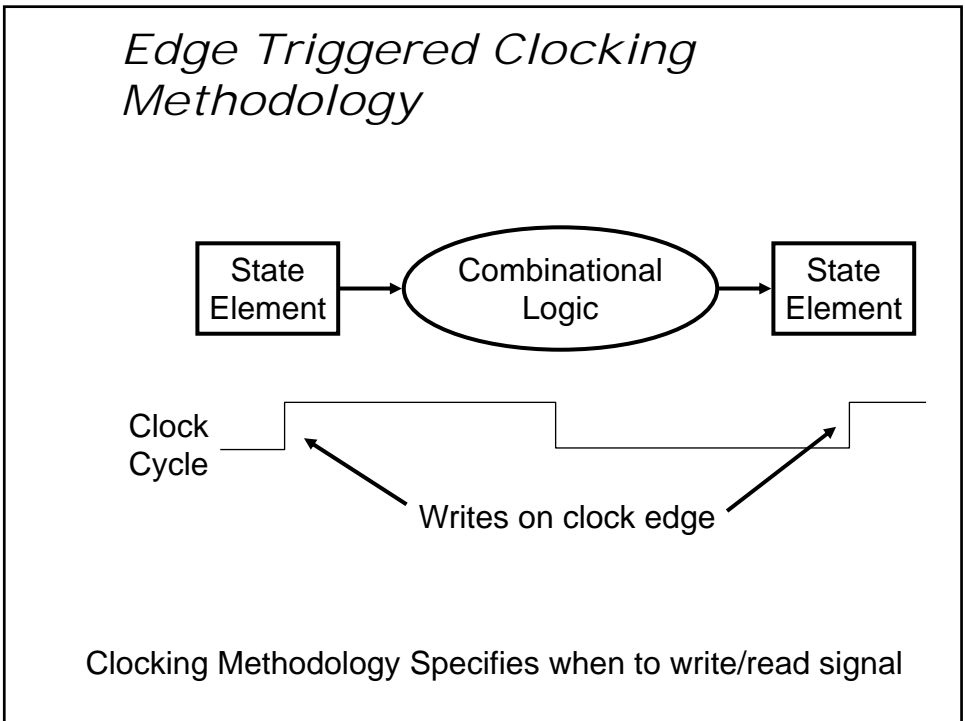
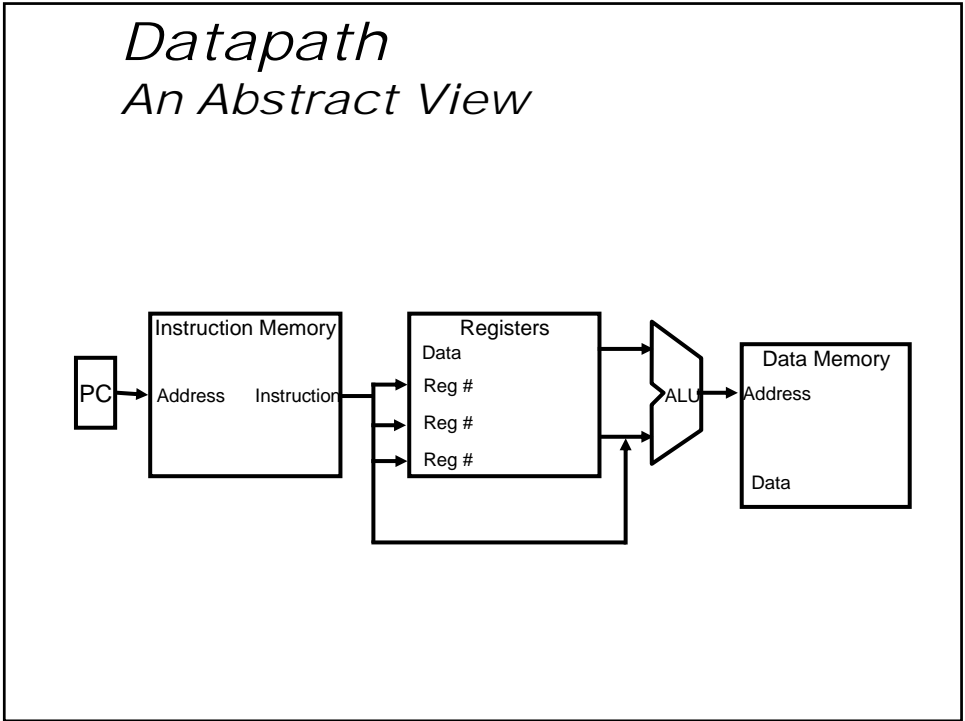

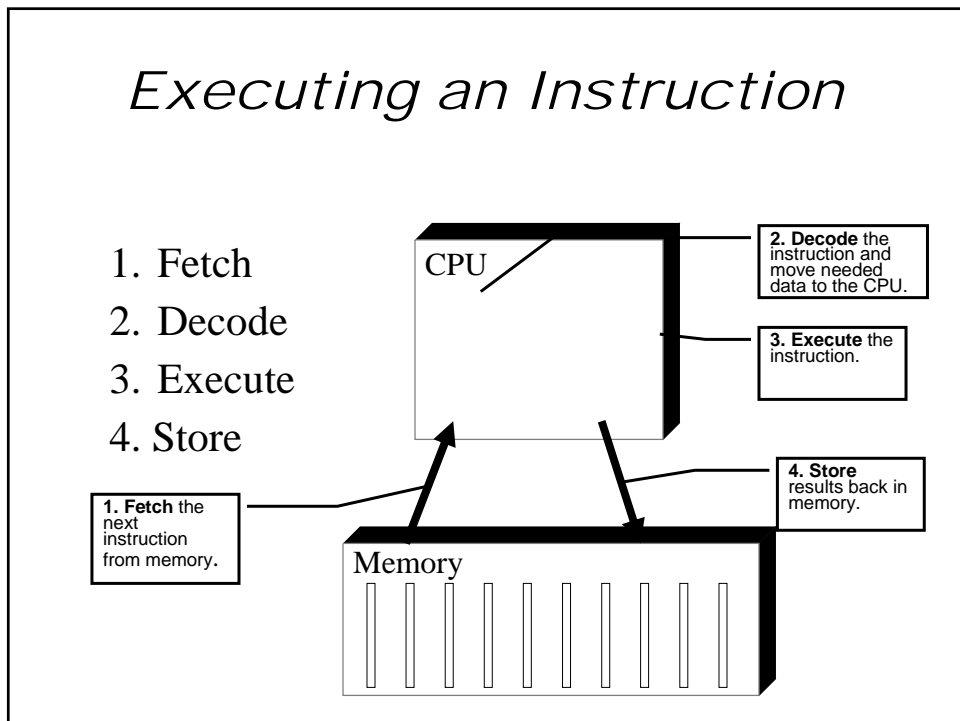
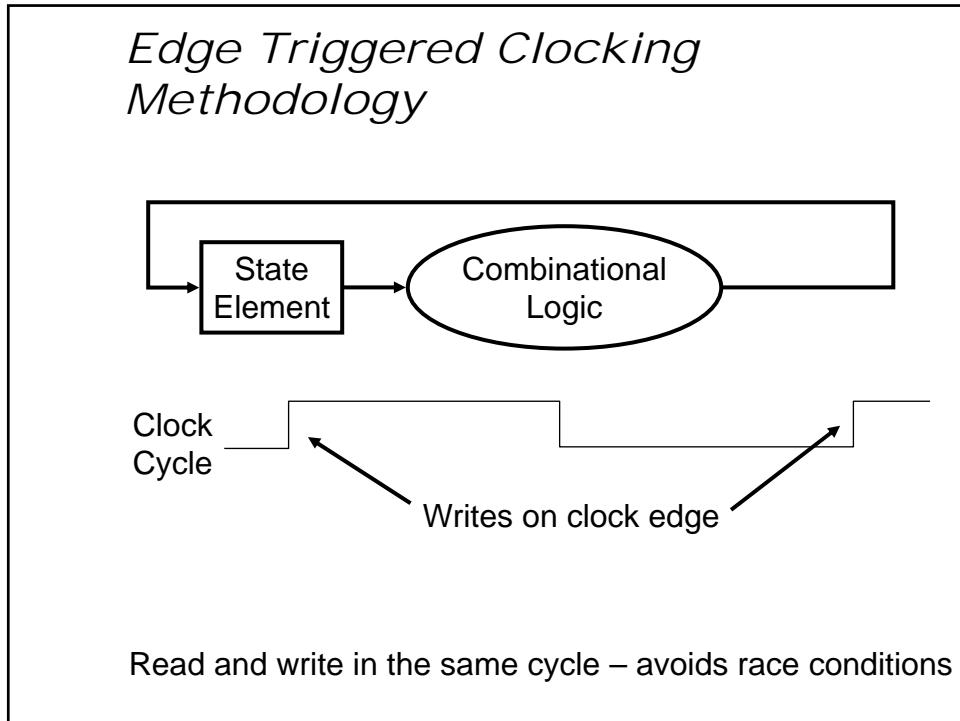

Datapath

Fetching Instructions

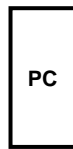

PC – Program counter holds the address of the current instruction

Datapath

Fetching Instructions

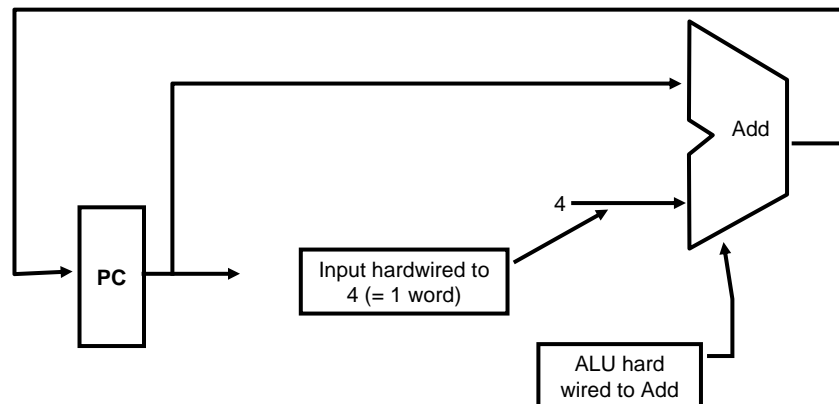

Usually, the PC should go to the next instruction – in MIPS this is the next word.

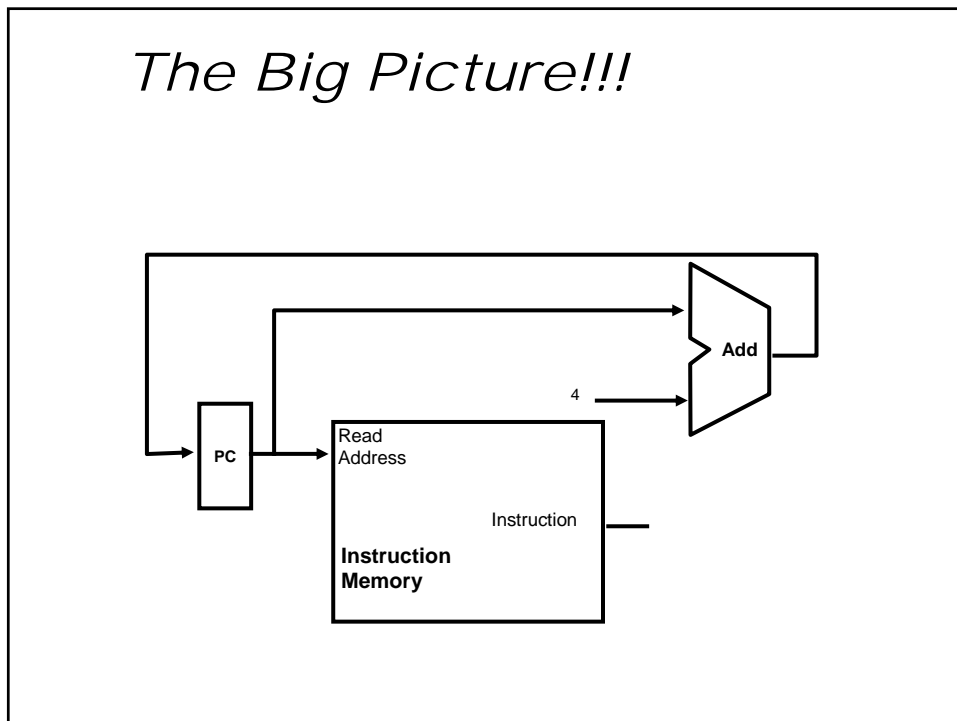
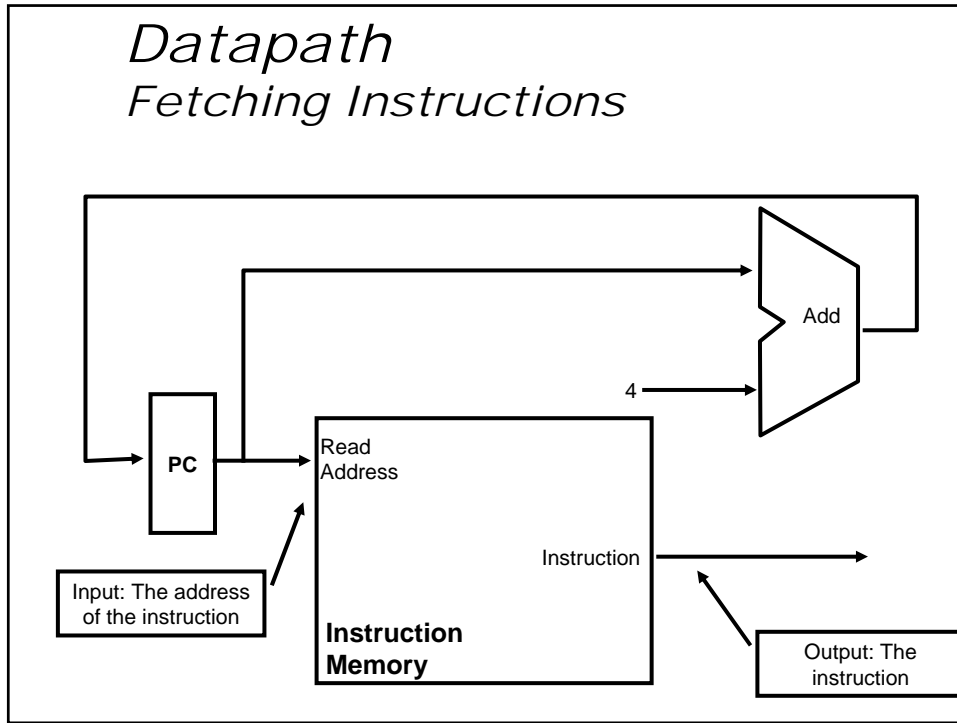

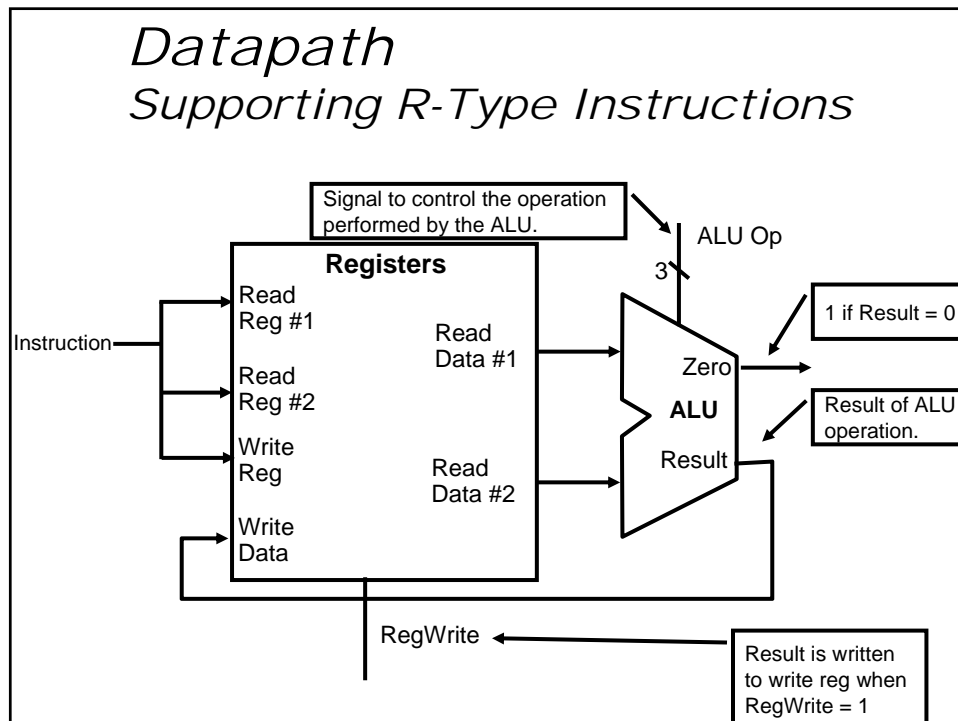
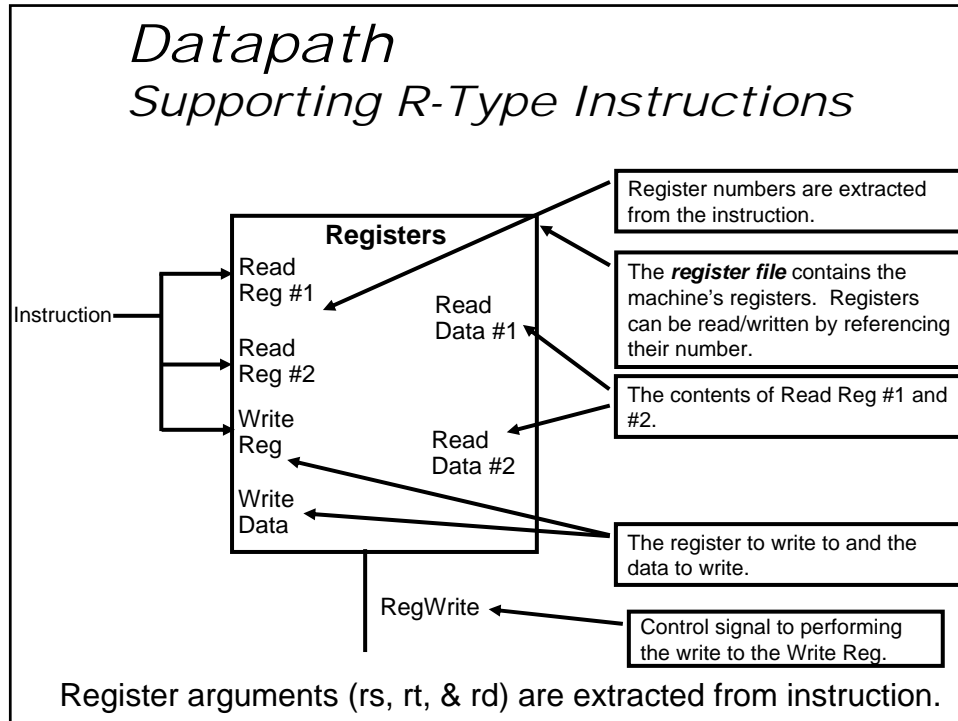

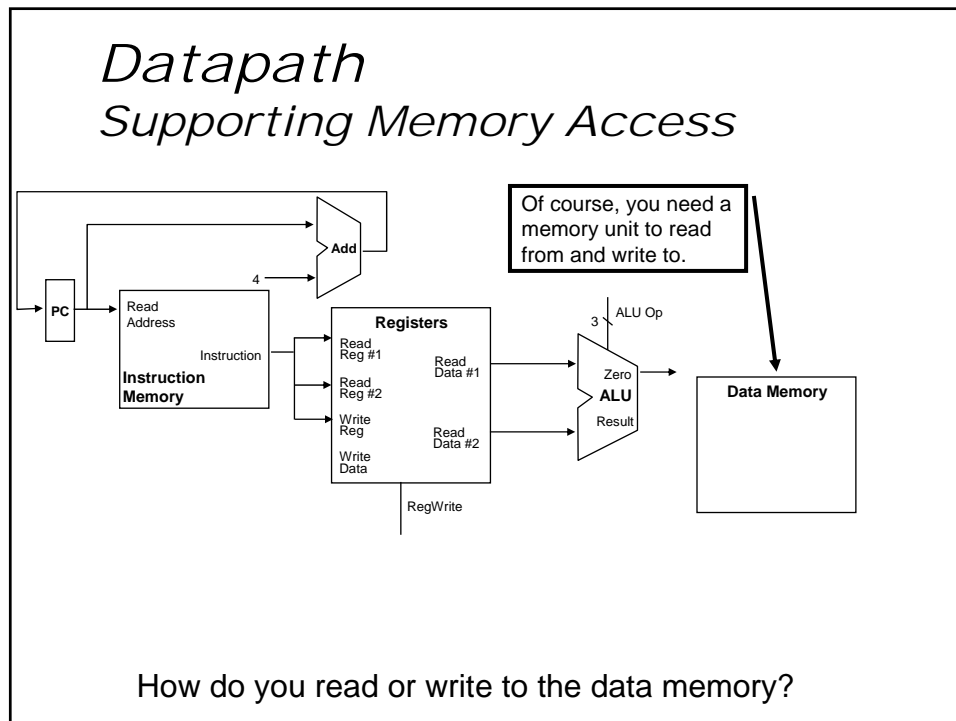
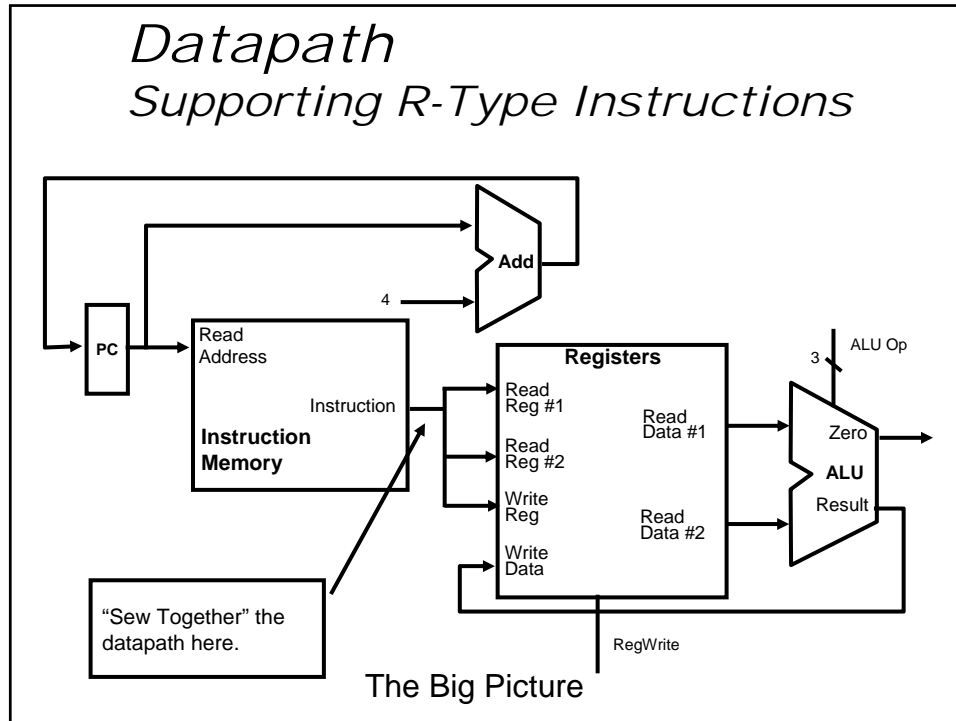

Datapath Supporting Memory Access

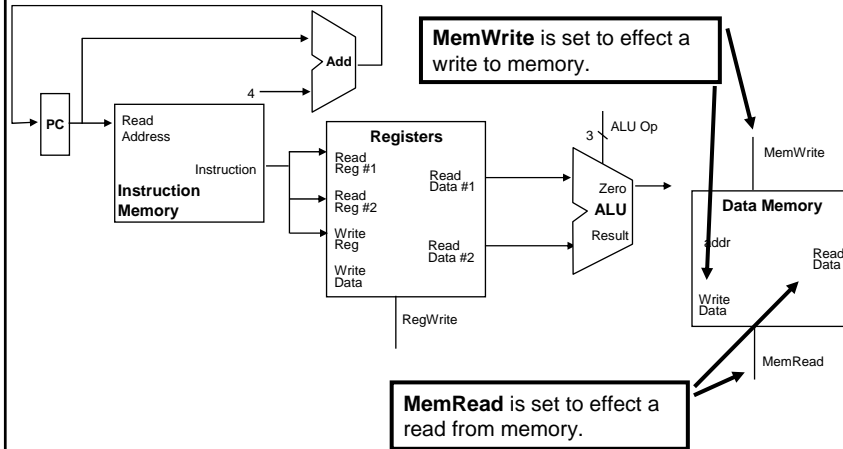

First, you need lines to control whether memory read from or written to

Datapath Supporting Load Instructions

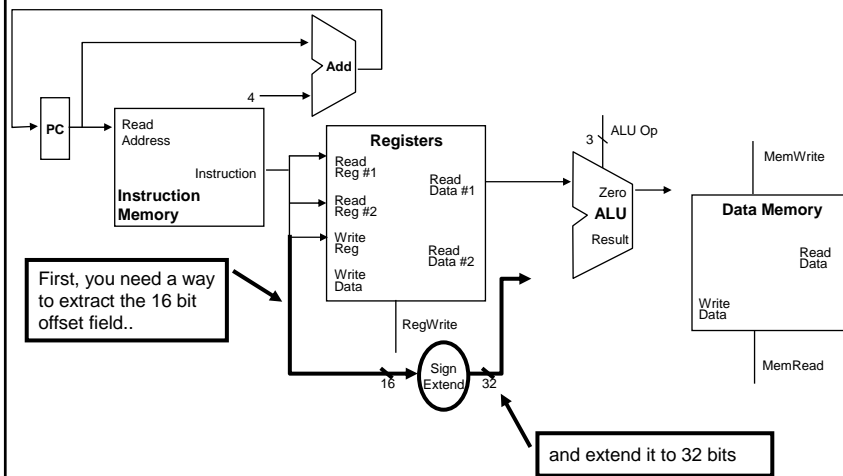

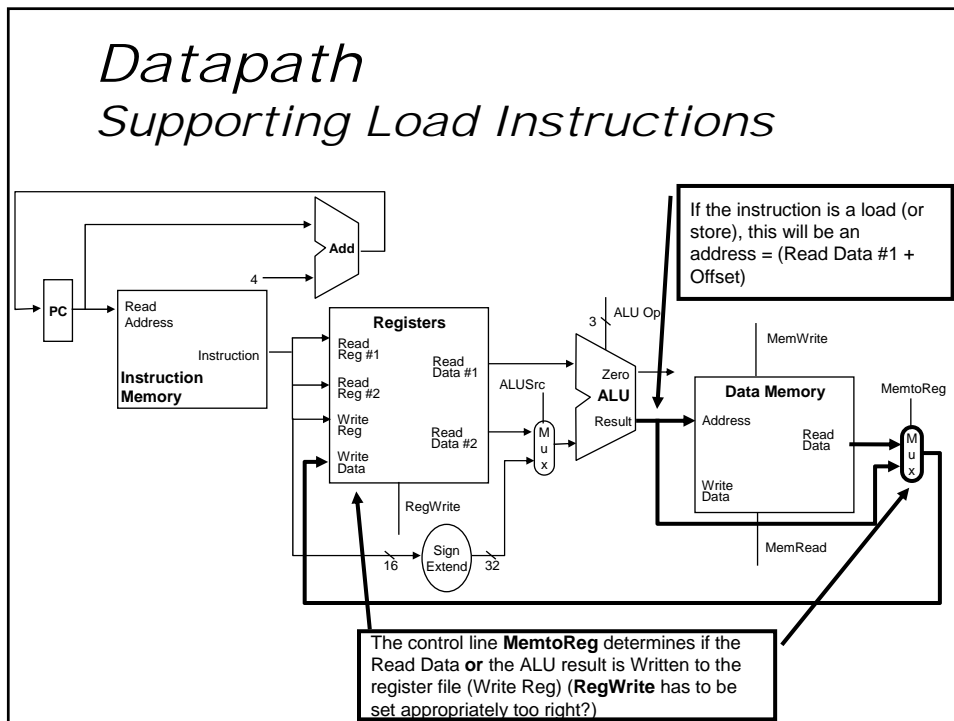
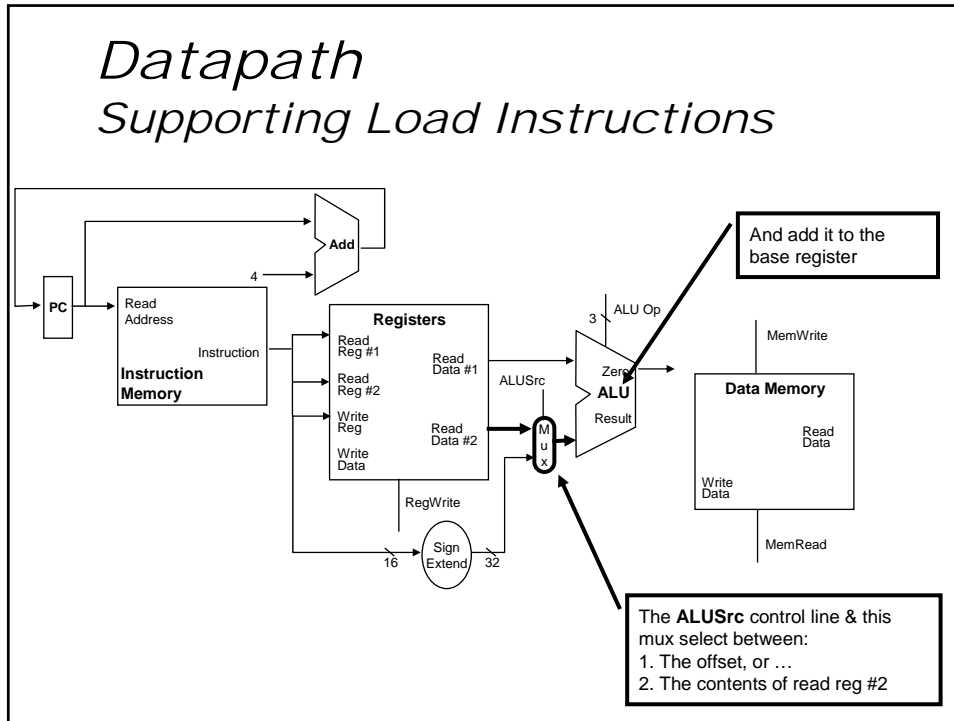

Datapath Supporting Store Instructions

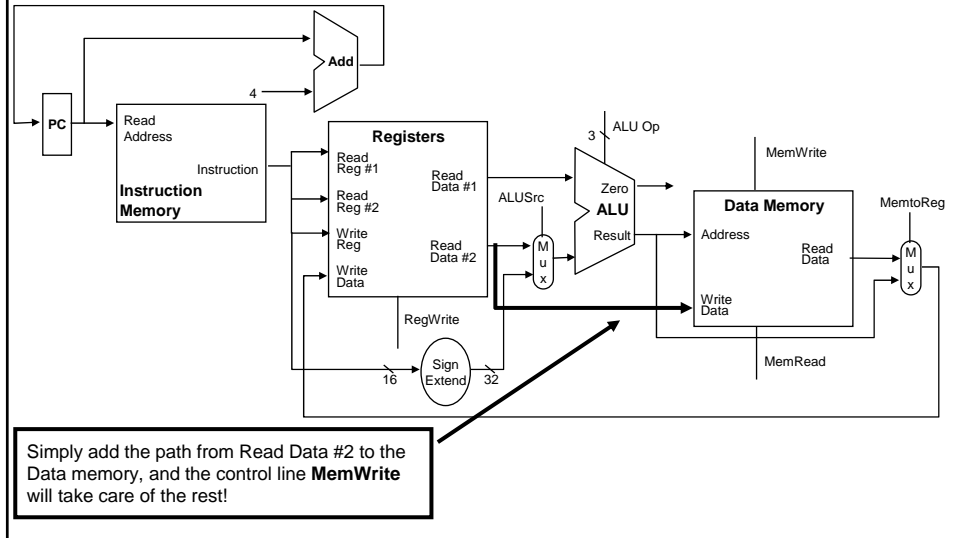

The Big Picture!!!

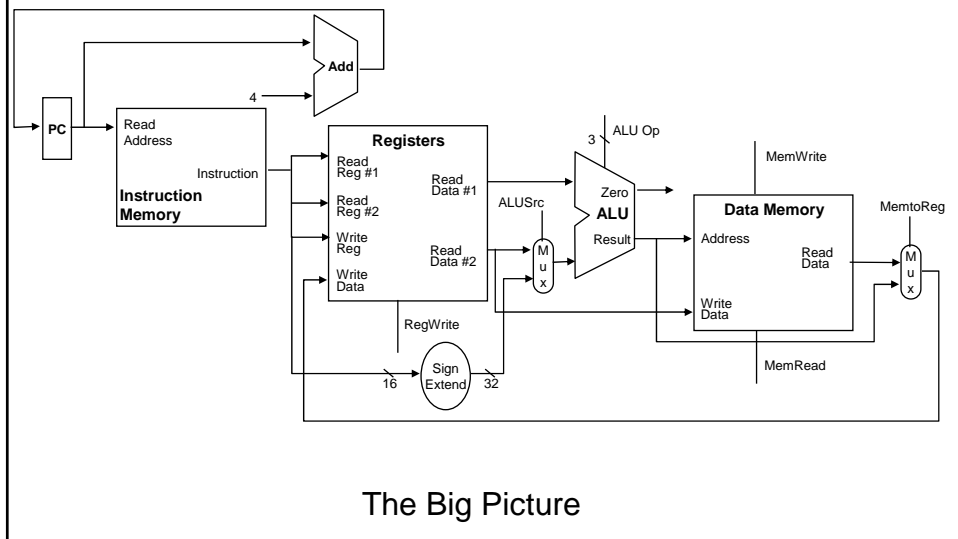

Datapath Supporting Branch Instructions

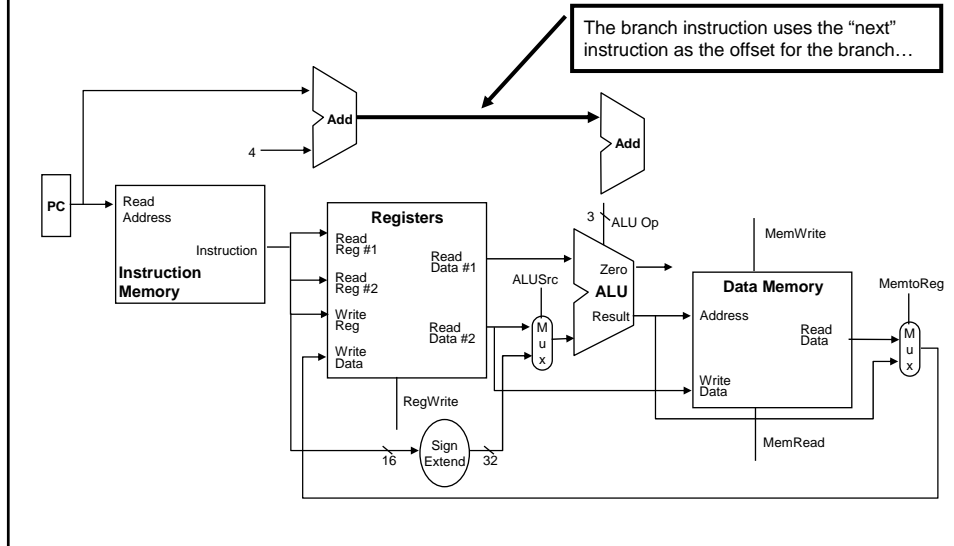

Datapath Supporting Branch Instructions

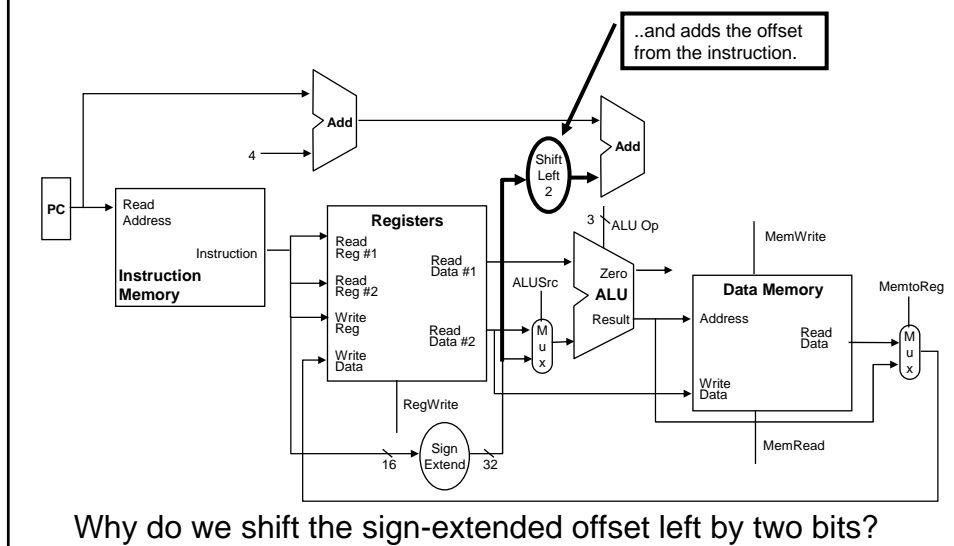

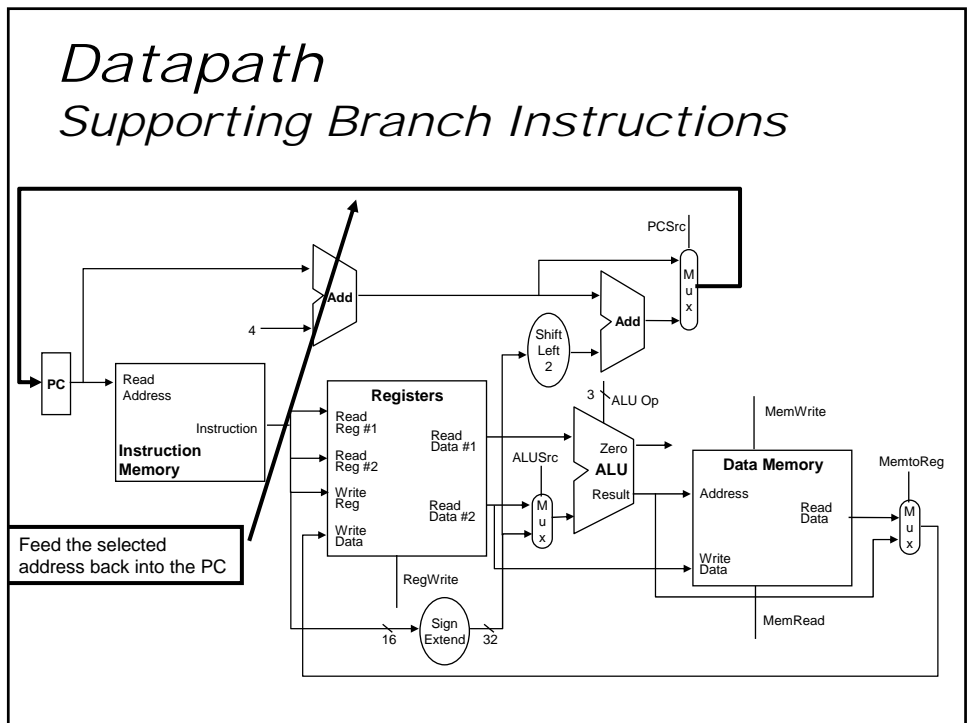
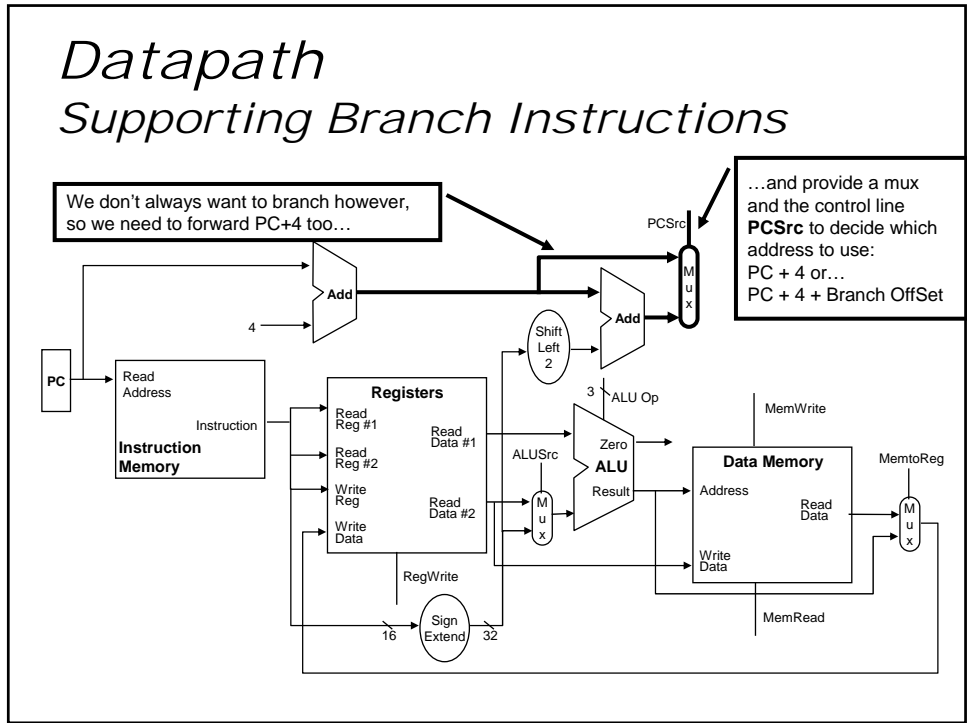

The Big Picture!!!

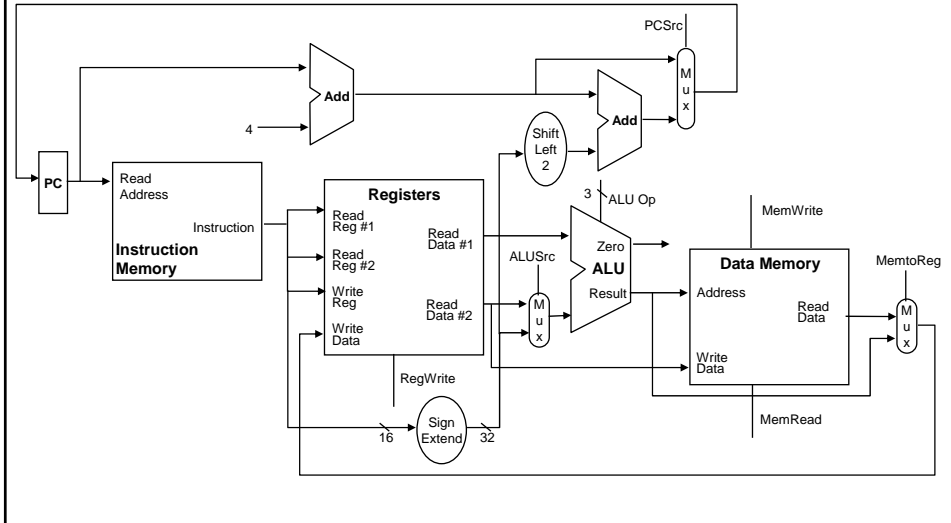

The Big Picture!!! Control

